

CARVIN

12340 World Trade Dr.
San Diego, CA. 92128
800-854-2235
carvin.com

CARVIN LH6000

UHF Wireless Microphone System



Carvin's Limited 90 Day Warranty

Carvin warrants to the original purchaser that your unit is free from any defects in material or workmanship for a period of 90 days from the date of purchase. If any such defect is discovered within the warranty period, Carvin will repair or replace the unit free of charge, subject to verification of the defect or malfunction upon delivery.

Important:

All items for service are to be return to **Carvin (shipped prepaid), 12340 World Trade Dr., San Diego CA. 92128**

This warranty does not apply to microphone capsules, nor to defects or physical damage from abuse, neglect, accident, being dropped or improper repair, alteration, or unreasonable use of the unit resulting in cracked or broken cases or parts, or units damaged by excessive heat, and does not apply to batteries or damage caused by leaking batteries. This warranty does not cover finish or appearance items nor items damaged during shipping en route to Carvin for repair.

If factory service is required, please contact our service department at **800-854-2235** to obtain a return authorization number (RA). Make sure the RA number is clearly marked on the outside of your package. If possible, please use your original packaging. Please include the Receiver, Transmitter and Power Supply. You must also include a photocopy of your proof of purchase or we cannot be responsible for repairs or replacements. Carvin will not replace nor be responsible for any units sent incomplete, without proper identification and return address or RA number clearly marked on the package.

Any applicable implied warranties including warranties of merchantability and fitness are hereby limited to 90 days from the date of purchase. Consequential or incidental damages resulting from a breach of any applicable express or implied warranties are hereby excluded. This warranty is in lieu of all other agreements and warranties, general or special, express or implied and no representative or person is authorized to assume for us any other liability in connection with the sale or use of this Carvin Wireless System.

CONTENTS

CONTENTS	3
INTRODUCTION	4
UH6000 RECEIVER	5
HANDHELD MICROPHONE	8
BODYPACK TRANSMITTER	9
SPECIFICATIONS	13
WARRANTY-SERVICE	14

Carvin wireless systems are type accepted under FCC rules, parts 90, 74 and 15.

This device complies with RSS-210 of Industry & Science Canada. Operation is subject to the following two conditions: (1) this device may not cause harmful interference; and (2) this device must accept any interference received, including interference that may cause undesired operation.

INTRODUCTION

Thank you for purchasing a Carvin UHF Diversity Wireless Microphone System and congratulations on your choice. The UH6000 is the best performance and price value available in rackmount UHF wireless systems and is loaded with features:

- Clear channel operation on the wide open, uncluttered UHF band for interference-free performance in any application or locale.
- Carvin's companding circuitry for an industry best 120dB Dynamic Range, and the clearest, most natural sound available.
- Tone Squelch™ for locking out potential interference.
- Choice of transmitters:
- Bodypack with unique 3-way switch for selecting input type: instrument (guitar, bass, etc.), headmic™ headworn mic, or lavalier mic.
- Handheld microphone with a powerful neodymium cartridge that delivers unsurpassed audio, minimal handling noise and enhanced feedback rejection.
- UH6000 receiver with DigiTRU Diversity™ for maximum range and dropout protection, full LED indicators, both 1/4" unbalanced and XLR balanced outputs, and special circuitry for noiseless transmitter ON/OFF switching.

SPECIFICATIONS

UH6000 RECEIVER

Frequency Response

50 Hz - 15 KHz, +/- 3 dB

Dynamic Range

120 dB

Total Harmonic Distortion

< 0.6%

RF Carrier Frequency Range

UHF, choice of single frequencies from 794-820 MHz

Frequency Stability

+/- 0.005% crystal controlled

Modulation

FM (F3E), +/- 20 KHz

Operating Range

Up to 250 feet typical (depending on site conditions)—up to 500+ feet line-of-sight

Reception Mode

DigiTRU Diversity™ (Dual Antenna)

Squelch

Tone Key (32.768 KHz), External Control

Controls

Power ON/OFF, Volume Control, Level Low/Hi Switch, Squelch (Mute) Adjust

Connectors

DC in, 1/4" (6.3 mm) unbalanced phone jack (750 mV/5K Ohm), XLR balanced output (60 mV/600 Ohm), A & B BNC antenna jacks, fuse

LED Indicators

Power ON, Diversity A/B, RF LEVEL and AF LEVEL (5 segment) displays

Unwanted Signal Rejection

60dB image and spurious

Power Requirements

DC 12-15V @ 300 mA, AC/DC adapter included

Dimensions

16" x 6.5" x 1.73"
(40.6 x 16.5 x 4.4 cm)

Fuse

20mm glass type, 250V, 500mA

Weight

3.93 lb (1.8 Kg)

TRANSMITTERS

Audio Inputs

Bodypack: 3.5mm locking mini-jack 3-way select switch for inputs: instrument, headworn mic, or lavalier mic
Handheld Mic: Integral neodymium dynamic cartridge

Controls

Bodypack: OFF/STANDBY/ON, INSTRUMENT/HEADWORN MIC/LAV MIC, INPUT LEVEL
Handheld Mic: OFF/STANDBY/ON

LED Indicator

Unit "ON" (single flash), Low Battery Alert (steady)

RF Power Out

50mW nominal (maximum allowed by FCC)

Harmonic & Spurious Emissions

< -50 dB

Battery

9V Alkaline

Battery Life

8-10 Hours (35mA draw typical)

Dimensions

Bodypack: 4.2" x 2.5" x .88"
(10.7 x 6.4 x 2.2 cm)

Handheld Mic: 9.5" x 1.37"
(24.1 x 3.48cm)

Weight

Bodypack: 3 oz (84g)

Handheld Mic: 7.5 oz (210g)

Specifications subject to change for product improvement purposes

UH6000 RECEIVER

1. Rackmounting the Receiver

The **UH6000** is supplied with RACK EARS (17) which can be attached with the screws provided on the front of the side panels to enable rackmounting the receiver. (Note: Do not mount the receiver in a rack directly above an amplifier or other source of high heat. Always ensure adequate air flow and heat dissipation in any rack configuration.)

2. Powering the Receiver

Plug the 12V AC/DC ADAPTER (15) provided into the DC INPUT JACK (11) on the back of the receiver. Then plug the power supply into an AC outlet. (Note: Any DC source with 300mA capability can also be used.) Press the POWER SWITCH (8) once to turn on the receiver. The POWER ON LED (7) will now light and the receiver is operational.

3. Antennas

The UH6000 receiver is supplied with two detachable ANTENNAS (16). These can be either rear-mounted (standard) on the BNC ANTENNA JACKS PROVIDED (9) or mounted on the front (when rackmounting the receiver) with the optional FR-2 FRONT-ANTENNA RACKMOUNT KIT (18). To use the FR-2 kit, attach these special rack ears to the front of the side panels of the receiver, as with the standard rack ears provided. Attach the two short cables supplied between each ANTENNA JACK (9) and the jacks on the back of the FR-2 RACK EARS (18). This will provide a connection between the FR-2 front-panel antenna jacks and the antenna jacks of the receiver. Connect the antennas to either these FR-2 jacks or the antenna jacks on the back of the receiver directly if not using the optional FR-2. Extend the TELESCOPIC ANTENNAS (16) fully to obtain maximum range. Optimal antenna position is 45 degrees from the receiver (at 90 degrees from each other).

4. Squelch Adjustment

In normal operation, the SQUELCH CONTROL (2) should be set fully clockwise to the factory preset RF level "10". However, in areas of high RF activity, the squelch (or mute, as it is sometimes called) may need to be adjusted to compensate for the adverse conditions in a particular location. If, with the transmitter off, the receiver's A and/or B DIVERSITY LED INDICATORS (3) and/or one or more LEDs of the 5 LED RF LEVEL (4) display flicker or stay on, the squelch control should be turned counterclockwise until the LEDs extinguish. When the squelch is properly adjusted, the A and/or B LEDs or the RF LEVEL LED displays will only light when the system transmitter is turned on. Turning the squelch control too far counterclockwise will reduce the range, but yield a quieter squelch (mute) function. During operation, especially at ranges greater than 75 feet, one or the other of the A or B LEDs may extinguish briefly. This is normal—the unit's DigitRU Diversity™ reception ensures that the received audio will not be interrupted. When both the A/B Diversity LEDs and the 5 LED RF LEVEL display extinguish, the transmitter is out of range for that given location, and the user should move closer to the receiver to re-establish the radio link.

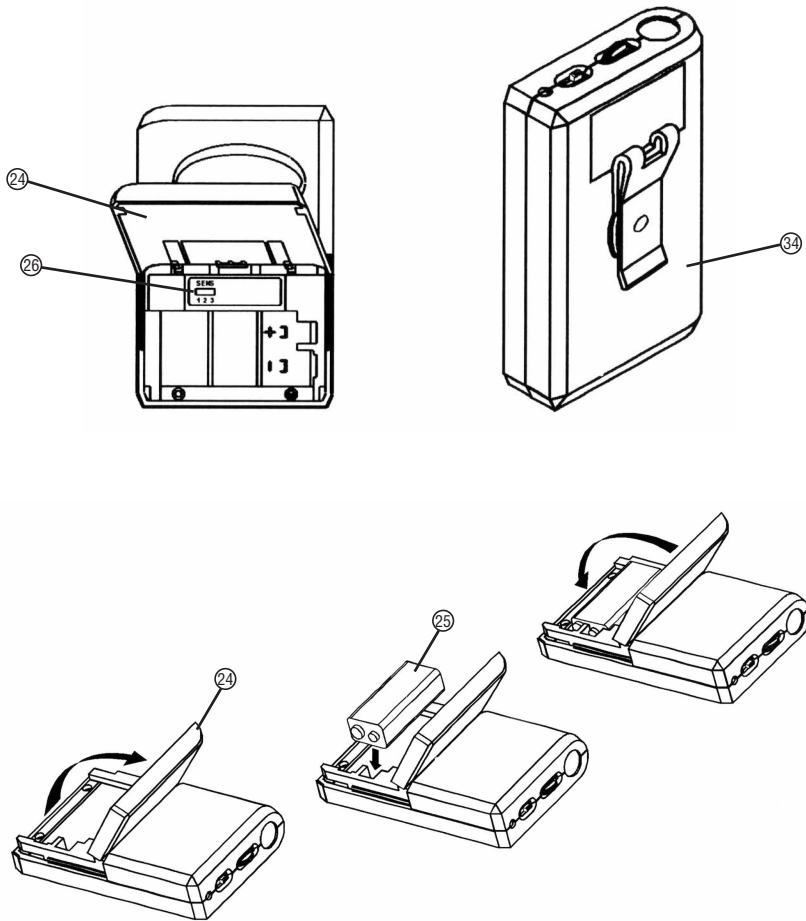

- 24. BATTERY COMPARTMENT
- 25. 9V ALKALINE BATTERY
- 26. INPUT SELECTOR SWITCH
- 27. 3.5mm LOCKING JACK
- 28. INSTRUMENT CORD
- 29. HEADWORN MIC
- 30. LAVALIER MIC
- 31. OFF/STANDBY/ON SWITCH
- 32. BATTERY INDICATOR LED
- 33. INPUT LEVEL CONTROL
- 34. CLIP

5. Connecting the Audio Output

The URR-10 receiver provides both a fixed mic level **BALANCED AUDIO OUTPUT XLR (14)** and an adjustable line level **UNBALANCED AUDIO OUTPUT 1/4" JACK (13)**. The level from the **UNBALANCED OUTPUT** is controlled by the front panel **VOLUME CONTROL (6)** and the rear panel **LEVEL LOW/HI SWITCH (12)**. This switch adjusts the maximum volume of the level range controlled by the **VOLUME CONTROL**. In the "LOW" position, the level of the signal from the **UNBALANCED OUTPUT**, with the **VOLUME CONTROL** set to "10", is about 10% of the maximum volume available with the "HI" position. Proper use of the **LOW/HI SWITCH** enables better control of the **UNBALANCED OUTPUT** volume.

(Note: As when making any connection, make sure the amplifier or mixing board volume is at the minimum level before plugging in the receiver to avoid possible sound system damage.)

Instrument Connection (using the Body Pack Transmitter in the "instrument" setting)

Insert an audio cord with a 1/4" mono phone plug in the **UNBALANCED OUTPUT JACK (13)** on the rear panel of the receiver. Plug the other end of the cord into an amplifier, effects, or mixing board. With the **LEVEL LOW/HI SWITCH (12)** set to HI, adjust the **VOLUME CONTROL (6)** on the receiver clockwise to about 3/4 rotation, until the volume level is comfortable for your application. This setting is roughly equivalent to a direct instrument cord connection. Turning the volume up to "10" will provide 4dB gain over a cord.

Microphone Connection (using the Body Pack Transmitter with either a headworn or lavalier microphone or the handheld microphone transmitter)

For microphone use, either the **BALANCED MIC AUDIO OUTPUT XLR (14)** or the 1/4" line level **UNBALANCED OUTPUT (13)** can be used. The XLR output is set at a non-adjustable microphone level, similar to hardwired mic levels. Plug an XLR connector into the XLR output jack on the rear of the unit and plug the other end into your amplifier or mixing board. Make sure the phantom power on your mixing board is turned off and the volume is turned down when making connections. For your convenience, the XLR output level is preset at the factory and is not adjustable with the receiver volume control.

To use the **1/4" UNBALANCED OUTPUT JACK (13)**, follow the instructions for the Instrument Connection (above), except start with the **LEVEL LOW/HI SWITCH** set to **LOW** and the receiver volume at 1/2 **MAX** and adjust both the switch and the volume control until the volume level is optimal. If the volume control is set too high, you may overload your mixer or amp.

The receiver is equipped with an **AF LEVEL LED DISPLAY (5)** which indicates the level of the received audio from the transmitter. There are 4 green and 1 red LED in this display and in normal operation they will go on and off with the changing signal level. If the top (red) LED stays on continuously, decrease the volume to the transmitter or overload distortion may result.

For optimum performance, an **INPUT LEVEL CONTROL (32)** is provided. Adjust the gain by turning the control with your thumb. For lavalier mic use, it is recommended that the level be set at about 2/3 maximum. For headworn mic use, it may be advisable to turn the gain down somewhat, depending on the volume levels expected. In either application, experiment and set for maximum possible gain without audible distortion on the high level peaks. (Note: Turning down the gain too much can compromise the signal-to-noise and is not recommended.)

The **AF LEVEL DISPLAY (5)** on the receiver will light up to 5 LED indicators for all input signals. Occasional flickering on and off during use of the top red LED is normal, but if the red LED stays lit continuously, turn down the **INPUT LEVEL CONTROL (33)** on the Body Pack Transmitter or noticeable distortion may result.

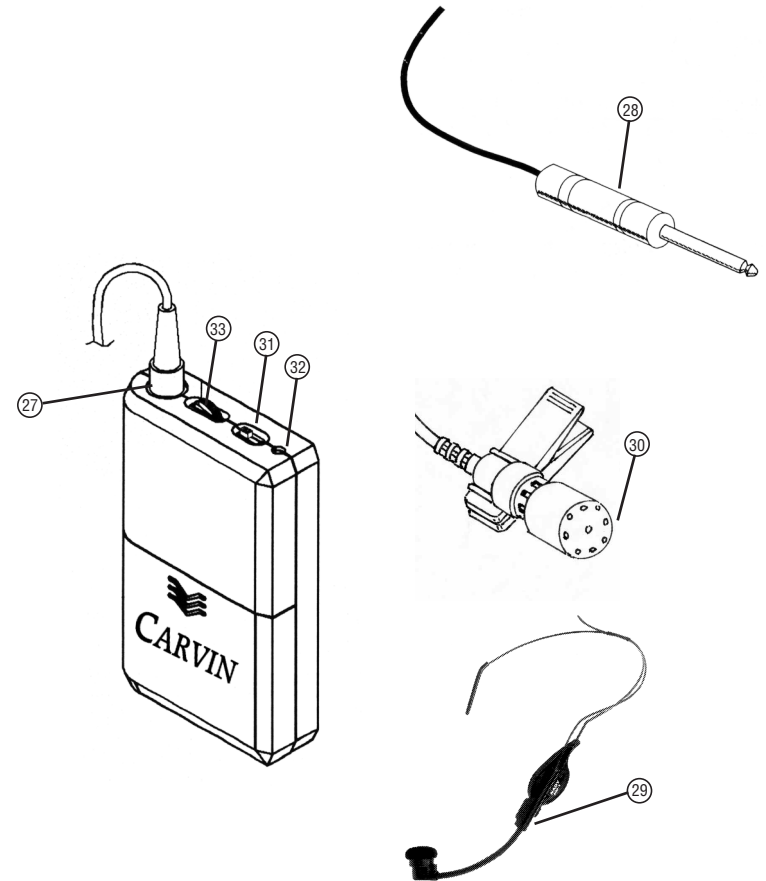

The **AF LEVEL LED DISPLAY (5)** on the receiver will light up to 5 LEDs for all input signals. Occasional flickering on and off during use of the top red LED indicator in this display is normal, however if the red LED stays on continuously, turn down the instrument volume or the **INPUT LEVEL CONTROL (33)** on the transmitter, or noticeable distortion may result. (Note: Scratchy noises can sometimes occur when some electric guitars with dirty pots or connections are used with any wireless system. For this reason, the supplied **INSTRUMENT CORD (28)** has a factory installed capacitor inside the 1/4" plug. This capacitor provides first order filtering of the RF signal from the cord into the guitar and eliminates virtually all scratchy noises. Should your equipment still give you scratchy noises, we suggest these steps to eliminate them:

- 1) Make sure all guitar volume and tone pots are clean and all contacts are solid—this is very important.
- 2) Provide extra filtering with a 47pf capacitor soldered across the hot to ground terminals of the guitar's volume and tone pots.)

6. Microphone Use (with either a lavalier or headworn microphone)

Secure the connection from the **LAVALIER (30)** or **HEADWORN MIC CORD (29)** by turning the slip ring on the plug into the transmitter clockwise to thread it on to the jack. To unplug, reverse the process. To use the lavalier mic, attach it at chest level. Do not place it too close to the mouth—a distance of about six inches usually works best. To use the headworn mic, place it on the head and adjust the boom so that the mic is about one inch to the side of the front of the mouth. When ready to speak, slide the **OFF/STANDBY/ON SWITCH (31)** to the ON position. Adjust the volume of the receiver as per the Audio Output Microphone Connection section of the above receiver instructions. *[Note: Observe care in selecting P.A. volume, transmitter location and speaker placement so that acoustic feedback (howling and screeching) will be avoided. Please also note the pickup pattern characteristics of the microphone selected. Omnidirectional mics pick up sound equally from all directions and are prone to feedback if not used carefully. Unidirectional mics are more resistant to feedback, but pick up sound sources best that are directly in front of the mic. Also, mics that are farther from the sound source, such as lavaliers, require more acoustic gain and thus are also more prone to feedback than close-source mics such as handheld or headworn models that are used close to the mouth].*

FRONT PANEL

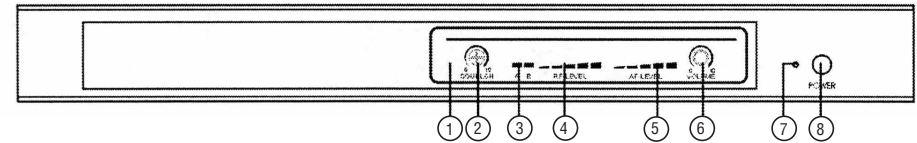

REAR PANEL

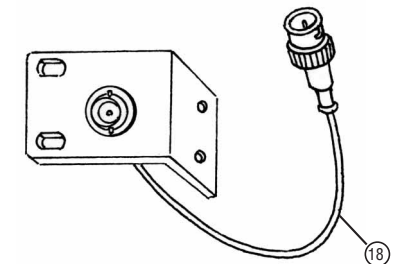
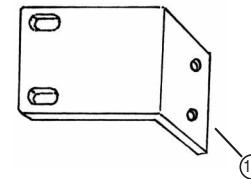
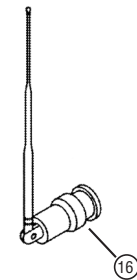
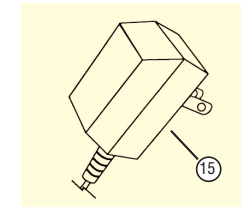
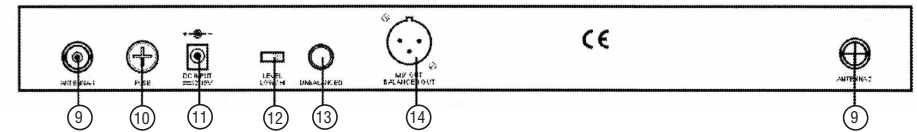

1. FRONT PANEL
2. SQUELCH CONTROL
3. A/B DIVERSITY LED INDICATORS
4. RF LEVEL LED INDICATORS
5. AF LEVEL LED INDICATORS
6. VOLUME CONTROL
7. POWER ON LED
8. POWER SWITCH
9. BNC ANTENNA JACK

10. FUSE
11. DC INPUT JACK
12. LEVEL LOW/HI SWITCH
13. UNBALANCED AUDIO OUT
14. BALANCED AUDIO OUT
15. 12-15 VDC ADAPTER
16. TELESCOPING ANTENNAS
17. STANDARD RACK EARS
18. FR-2 FRONT-ANTENNA RACK KIT

HANDHELD MICROPHONE

1. Unscrew the **BATTERY COMPARTMENT COVER (19)** and remove, exposing the **BATTERY HOLDER (20)**. Insert a fresh **9V ALKALINE BATTERY (21)**, observing the correct polarity as marked, and screw the cover back on to the microphone. Make sure the cover is screwed on completely. A fresh alkaline battery can last up to 10 hours in use, but in order to ensure optimum performance, it is recommended that you replace the battery after every 7-8 hours of use.
2. Turn on the UH-10 by sliding the **OFF/STANDBY/ON SWITCH (22)** to the STANDBY position (transmitter on, audio muted) or the ON position (transmitter and audio both on). The **BATTERY INDICATOR LED (23)** will give a single quick flash, indicating usable battery strength. In the case of a dead or low battery, the LED will either not go on at all or will stay on continuously, indicating that the battery should be replaced with a fresh one. To preserve battery life, turn the transmitter off when not in use.
3. The microphone is now ready to use. The A and/or B **DIVERSITY LED INDICATORS (3)** and most or all of the **RF LEVEL DISPLAY LEDS (4)** on the receiver should now be lit, indicating a received signal from the transmitter. When ready to speak, slide the transmitter switch to the ON position. Adjust the volume of the receiver as per the Audio Output Microphone Connection section of the above URR-10 receiver instructions. *[Note: Observe care in selecting P.A. volume, transmitter location and speaker placement so that acoustic feedback (howling or screeching) will be avoided.]*

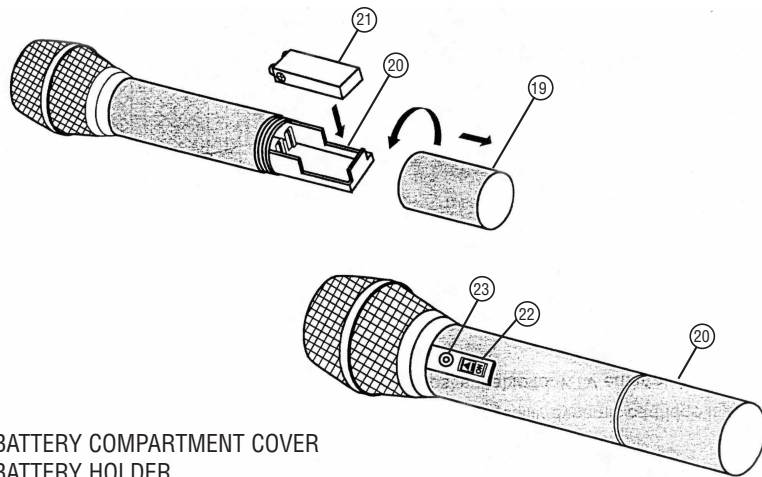

- 19. BATTERY COMPARTMENT COVER
- 20. BATTERY HOLDER
- 21. 9V ALKALINE BATTERY
- 22. OFF/STANDBY/ON SWITCH
- 23. BATTERY INDICATOR LED

BODYPACK TRANSMITTER

1. Slide open the hinged **BATTERY COMPARTMENT (24)** and insert a fresh 9V ALKALINE BATTERY (25), observing the correct polarity. A fresh alkaline battery can last up to 10 hours in use, but in order to ensure optimum performance, it is recommended that the battery be replaced after 7-8 hours of use.
2. The Bodypack Transmitter is equipped with an **INPUT SELECTOR SWITCH (26)** in the battery compartment for selecting the type of audio input you will be supplying to the transmitter. Select from the choice of three positions: INSTRUMENT (for guitar, bass, etc.)/ HEADWORN MIC/ LAVALIER MIC.
3. The Bodypack Transmitter is provided with a 3.5 mm **LOCKING JACK (27)** for connecting the audio input selected. Connect either the **INSTRUMENT CORD (28)** or the **HEADWORN MIC (29)** or **LAVALIER MIC CORD (30)** as desired, according to the input selected. *(Note: Use only the input audio source as per the input selected with the AUDIO INPUT SELECTOR SWITCH or the audio will not be optimal—a muddy or distorted sound may result.) To secure the connection, turn the slip ring on the plug clockwise to thread it on the jack. To unplug, reverse the process. Slip the transmitter into a pocket or use CLIP (34) to attach it to your clothes or instrument strap (if using as an instrument transmitter).*
4. Turn on the Bodypack Transmitter by sliding the **OFF/STANDBY/ON SWITCH (31)** to the STANDBY position (transmitter on, audio muted) or the ON position (transmitter and audio both on). The **BATTERY INDICATOR LED (32)** will give a single quick flash, indicating usable battery strength. In the case of a dead or low battery, the LED either will not go on at all or will stay on continuously, indicating that the battery should be replaced with a fresh one. To preserve battery life, turn the transmitter off when not in use. The transmitter is now ready to use. The A and/or B **DIVERSITY LED INDICATORS (3)** and most or all of the **RF DISPLAY LEDS (4)** on the receiver should now be lit, indicating a received signal from the transmitter.
5. **Instrument Use**
Plug the 1/4" phone plug from the **INSTRUMENT CORD (28)** into the instrument. As the cord to the instrument also serves as the antenna, be sure to extend it fully for maximum range. Rolling up or shortening the cord may reduce the effective operating range. When ready to play, slide the audio **OFF/STANDBY/ON SWITCH (31)** to the ON position. Adjust the volume of the receiver as per the Audio Output Instrument Connections section of the above receiver instructions. For optimum performance, an **INPUT LEVEL CONTROL (33)** is provided on the top panel of the Bodypack transmitter. Adjust the gain by turning the control with your thumb. For instrument use, it is recommended that this control be turned to maximum gain. However, for ultra high-gain instrument sources such as active bass pickups or even extra hot guitar pickups, turning the level down slightly will create a cleaner sound. *(Note: Turning down the input gain too much can compromise the signal-to-noise ratio and is not recommended. Set for the maximum possible gain and headroom without noticeable distortion on the high level peaks).*