

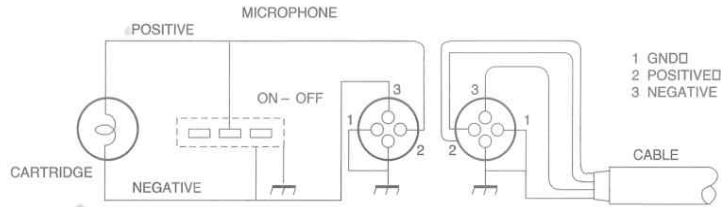

**UNIDIRECTIONAL DYNAMIC MICROPHONE**

**INTERNAL CONNECTIONS**



**MODEL CM50**

The Carvin M50 is a rugged unidirectional microphone with a highly effective built-in wind and "pop" filter. It is mostly suited for vocals but can also double as an instrument mic. We recommend this microphone to performers who work close to their mics, where high volumes can be obtained without distortion or explosive breath "pop's". An excellent choice for club use, rock singers, or any vocalist requiring the best in vocal reproductions. Designed for high end studio recording and broadcast applications.

**Microphone Features:**

- Bright, clean sound. Especially good for announcing, narration and dialogue, vocal music, and rhythm pickups
- Wind and "pop" filter readily removable for cleaning or replacement
- Unusually effective cardioid pickup pattern to minimize background noise and undesirable effects of studio and location acoustics. Rear and side rejection uniform to very low frequencies and completely symmetrical about microphone axis
- Self-contained spherical filter to control explosive breath sounds ("pop") and wind noise in outdoor locations
- Cartridge shock-mounted for protection and quiet operation
- On/Off switch

**Polar Pattern**

Cardioid — rotationally symmetrical about microphone axis, uniform with frequency (see Figure 2)

**TYPICAL POLAR PATTERNS**

**FIGURE 2**

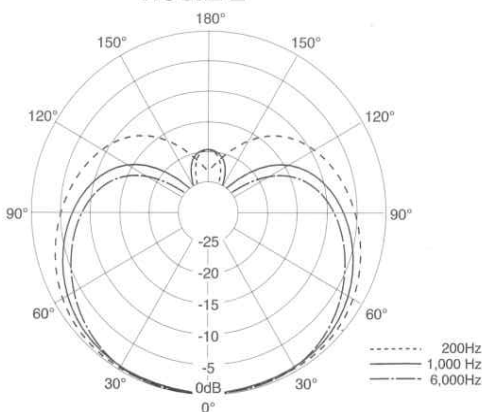

**ARCHITECT'S SPECIFICATIONS**

The microphone shall be a moving coil (dynamic) type with a frequency response of 45 to 15,000 Hz. The unit shall have a cardioid polar characteristic. The cancellation at the sides shall be approximately 5 dB and the cancellation at the rear shall be 15 to 20 dB. The microphone shall have a rating impedance of 300 ohms designed for 600 ohmspreamps

The microphone connector shall be a 3-pin professional audio type designed to mate with a XLR male connector. The microphone shall be provided with a swivel adapter adjustable through 90° from vertical to horizontal. The adapter will mount on a stand having a 5/8"-27 thread. The overall dimensions of the microphone shall be 5.125" (130 mm) in length and 2.080" (53 mm) in diameter.

**GUARANTEE**

This Carvin product is guaranteed to be free from electrical and mechanical defects for a period of one year from date of purchase. Microphones dropped, misused or exposed to moisture are not covered under warranty. Please retain proof of purchase date. This guarantee includes parts and labor.

This guarantee is in lieu of any and all other guarantees or warranties, express or implied, and there shall be no recovery for any consequential or incidental damages.

**SHIPPING INSTRUCTIONS**

Carefully repack the unit, have it insured, and return it prepaid to:

Carvin  
Service Department  
12340 World Trade Drive  
San Diego, CA 92128

**M50 FREQUENCY RESPONSE**

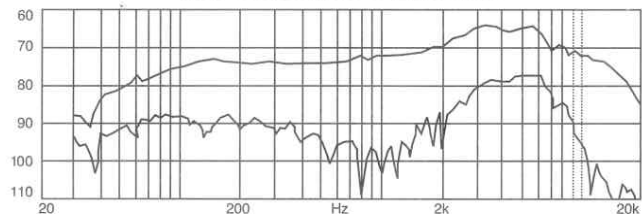

**MODEL CM50 UNIDIRECTIONAL DYNAMIC MICROPHONE SPECS:**

- Type:** Dynamic
- Frequency Response:** 50 to 15,000HZ
- Output Level** (at 1,000 Hz, 600 ohms): Open Circuit Voltage\* -72 dB, (0.19 mV)
- Cable: M50:** 6.0m (20 ft) three-conductor shielded broadcast type with XLR professional audio connector\*
- Case:** Grey powder coat die casting and steel mesh grille
- Swivel Adapter:** Slip-in positive-action, adjustable from 0° to 90°, with standard 5/8"-27 thread
- Net Weight:** (less cable) 8.5 oz.

**CARVIN**

12340 World Trade Drive, San Diego, CA 92128  
800.854.2235 carvin.com